

UNCONTROLLED DOCUMENT

PART NUMBER
SSL-LX100133SRD

REV.

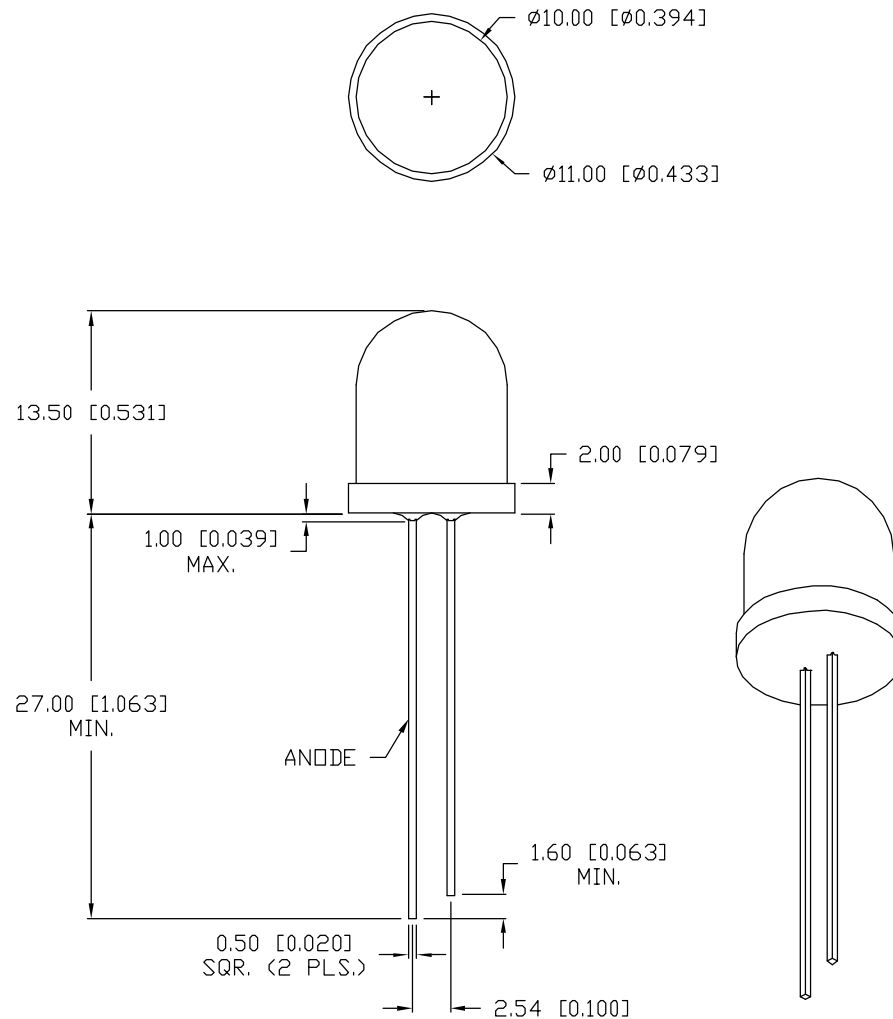

ELECTRO-OPTICAL CHARACTERISTICS $T_A=25^\circ\text{C}$ $I_f=20\text{mA}$

| PARAMETER | MIN | TYP | MAX | UNITS | TEST COND |
|--------------------|--------------|-----|-----|----------|----------------------|
| PEAK WAVELENGTH | | 660 | | nm | |
| FORWARD VOLTAGE | | 1.7 | 2.2 | V_f | |
| REVERSE VOLTAGE | 4.0 | | | V_r | $I_r=100\mu\text{A}$ |
| AXIAL INTENSITY | | 550 | | mcd | $I_f=20\text{mA}$ |
| VIEWING ANGLE | | 60 | | 2x theta | |
| EMITTED COLOR: | RED | | | | |
| EPOXY LENS FINISH: | RED DIFFUSED | | | | |

LIMITS OF SAFE OPERATION AT 25°C

| PARAMETER | MAX | UNITS |
|--------------------------------|------------|----------------------|
| PEAK FORWARD CURRENT* | 150 | mA |
| STEADY CURRENT | 30 | mA |
| POWER DISSIPATION | 75 | mW |
| DERATE FROM 25°C | -1.2 | mW/ $^\circ\text{C}$ |
| OPERATING, STORAGE TEMP. | -40 TO +85 | $^\circ\text{C}$ |
| SOLDERING TEMP. | +260 | $^\circ\text{C}$ |
| 2.0mm FROM BODY | | 3 SEC. MAX |

* $t < 10\mu\text{s}$

*UNLESS OTHERWISE SPECIFIED TOLERANCES PER DECIMAL PRECISION ARE: X= ± 1 (± 0.039), X.X= ± 0.5 (± 0.020), X.XX= ± 0.25 (± 0.010), X.XXX= ± 0.127 (± 0.005). LEAD SIZE= ± 0.05 (± 0.002), LEAD LENGTH= ± 0.75 (± 0.030). MIN= $\frac{+DECIMAL}{-0.00}$ PRECISION MAX.= $\frac{+0.00}{-DECIMAL}$ PRECISION

UNCONTROLLED DOCUMENT

REV.

PART NUMBER
SSL-LX100133SRD

CONFIDENTIAL INFORMATION
THE INFORMATION CONTAINED IN THIS DOCUMENT IS THE PROPERTY OF LUMEX INC. EXCEPT AS SPECIFICALLY AUTHORIZED IN WRITING BY LUMEX INC., THE HOLDER OF THIS DOCUMENT SHALL KEEP ALL INFORMATION CONTAINED HEREIN CONFIDENTIAL AND SHALL PROTECT SAME IN WHOLE OR IN PART FROM DISCLOSURE AND DISSEMINATION TO ALL THIRD PARTIES.



290 E. HELEN ROAD
PALATINE, IL 60067-6976
PHONE: +1.847.359.2790
US WEB: www.lumex.com
TW WEB: www.lumex.com.tw

T-10mm (T-3 1/8) 660nm SUPER RED LED,
RED DIFFUSED LENS.

RELIABILITY NOTE
OUR MANY YEARS OF EXPERIENCE DATA ACCUMULATION INDICATE THAT SOLDER HEAT IS A MAJOR CAUSE OF EARLY AND FUTURE FAILURE. PLEASE PAY ATTENTION TO YOUR SOLDERING PROCESS.

| | | | |
|-----------------|-------------|--------------|---------------|
| DRAWN BY: CT | CHECKED BY: | APPROVED BY: | DATE: 4.14.03 |
| | | | PAGE: 1 OF 1 |
| | | | SCALE: N/A |